

17. Transmembrane proteins are involved in the transport of sugars across the plasma membrane.

Glucose can be moved into cells by facilitated diffusion using proteins called GLUT proteins. These proteins expose a single binding site on one side of the membrane. Glucose binds to this site and causes a change in the shape of the protein. This change moves the glucose across the membrane and releases it on the other side.

- i. Explain why facilitated diffusion via GLUT proteins requires no metabolic energy.

[2]

- ii. Glucose can also be absorbed by an active process which requires metabolic energy. What is the immediate source of this energy in cells?

[1]

- iii. Explain why glucose cannot pass through a cell membrane by simple diffusion.

[2]

18. Chromista are photosynthetic protocists that live in water.

Fig. 17.2 is a diagram of part of the plasma membrane of a Chromista cell.

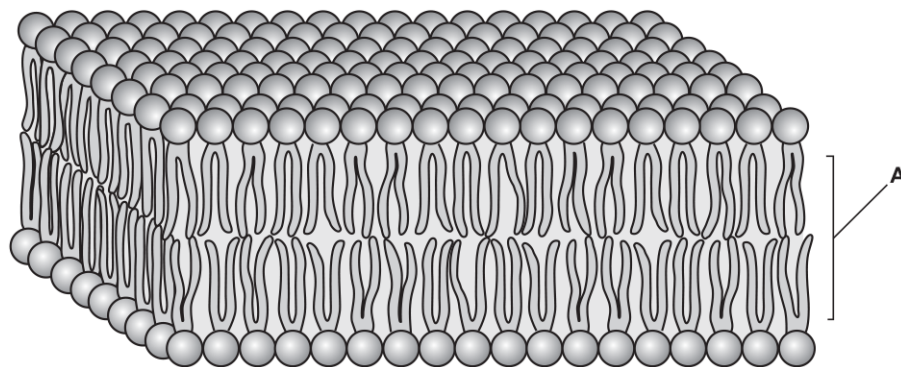

Fig. 17.2

i. State and explain how **one** property of region **A** in Fig. 17.2 contributes to the stability of the plasma membrane.

[2]

ii. There are differences between the plasma membrane and membranes within cells.
Outline the role of membranes **within** cells.

[2]

19. The rough endoplasmic reticulum is where translation of some proteins takes place in a eukaryotic cell.

Explain the role of the membrane in the rough endoplasmic reticulum.

[2]

20. Milk contains lactose. Lactose cannot be absorbed in the small intestine. The intestinal cells of mammalian infants produce lactase, an enzyme that splits lactose into glucose and galactose. These monosaccharides can pass into the blood.

Fig. 18.1 shows a molecule of the disaccharide lactose and the products of its breakdown in digestion.

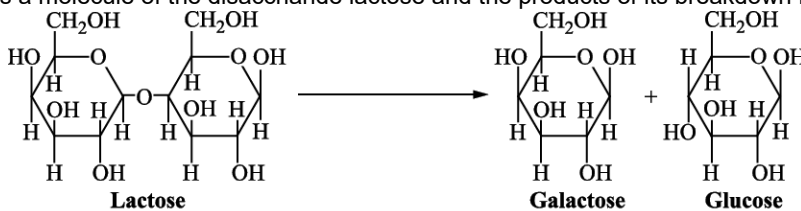

Fig. 18.1

i. Suggest why galactose and glucose cannot pass through the plasma membrane into intestinal cells by simple diffusion through the phospholipid bi-layer.

[1]

ii. What two substances are required to break the glycosidic bond in lactose?

1:

2:

[1]

21. The permeability of plasma membranes can be investigated using beetroot.

Beetroot cells contain a red pigment. The red pigment leaks out of the cells only when the plasma membrane has become damaged.

Some students investigated the effect of pH on the permeability of plasma membranes in beetroot cells.

The students used a valid method for the investigation, which is outlined below:

- Equal-sized disks of beetroot were cut.
- The disks were each immersed in an equal volume of buffer solution.
- After a set time, the solution was stirred and the absorbance measured using a colorimeter.
- The procedure was replicated three times in each of six different pH buffers.

The students recorded their results in the format shown below.

pH2 - 80%, 78%, 78%: average = 78.67%
 pH3 - 61%, 60%, 60%: average = 60.33%
 pH4 - 19%, 23%, 22%: average = 21.33%
 pH5 - 9%, 10%, 11%: average = 10 %
 pH6 - 0%, 0%, 0%: average = 0
 pH7 - 0%, 0%, 0%: average = 0

- i. Present the students' results in an appropriate table in the space below.

[4]

- ii. The students concluded that the red pigment began to leak out of the beetroot cells at any pH below pH6.

Suggest and explain why a low pH might cause the red pigment to leak out of the beetroot cells.

[2]

- iii. Outline how the students could modify their investigation to get a more accurate value for the pH at which the red pigment begins to leak out of the beetroot cells.

[2]

22(a). Plasma membranes are partially permeable, allowing some molecules to cross the membrane with relative ease.

One molecule that crosses membranes easily is the steroid hormone progesterone which is produced in the ovaries from cholesterol.

- i. Explain why progesterone can move across membranes.

[2]

- ii. Name one other molecule that can cross plasma membranes.

[1]

(b). Potassium ions are unable to move across membranes as they are charged.

- i. State how the structure of the cell surface membrane allows potassium ions to enter or leave a cell.

[1]

- ii. The process of active transport uses ATP to pump potassium ions through the cell surface membrane against the concentration gradient.

ATP is made up of phosphate groups and two other molecules.
Name the **two** other molecules.

1:

2:

[2]

- (c). The fluid mosaic model describes plasma membranes of all living organisms.

How does the fluid mosaic model describe the structure of plasma membranes?

[2]

- 23.** Cells are surrounded by a plasma membrane that contains phospholipids.

Explain how the structure of phospholipid molecules allows for the formation of plasma membranes.

[3]

- iii. Sulthiame is a drug that inhibits the enzyme carbonic anhydrase.

Fig. 2.2 shows the role of carbonic anhydrase in the PCT of the kidney.

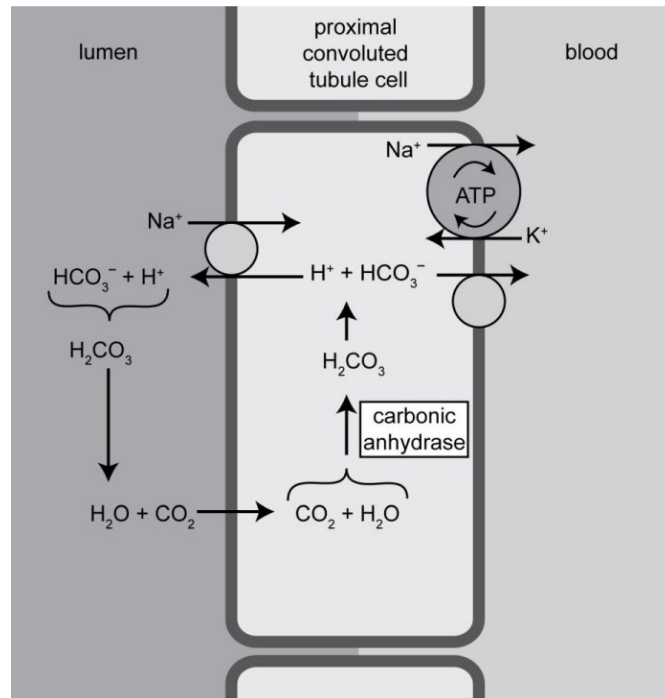

Fig. 2.2

Using the information in Fig. 2.2, what can you conclude about the likely effect of sulthiame on the reabsorption of sodium ions in the PCT?

26. This question is about the impact of potentially harmful chemicals and microorganisms.

- i. Salts that a plant needs, such as nitrates and phosphates, are taken into root hair cells by active transport.

For which macromolecule does a plant need both nitrogen **and** phosphorus?

[1]

- ii. Flooding of fields by seawater can damage crops. Seawater contains dissolved salts, including sodium chloride.

How would flooding affect soil water potential?

[1]

- iii. Sodium chloride in solution dissociates into Na^+ and Cl^- .

Explain how the Casparian strip prevents these ions from reaching the xylem of the plant by the apoplast pathway.

[2]

27(a). A student carried out an investigation into the effect of ethanol on the permeability of cell membranes in beetroot.

The student's method comprised the following five steps:

1. Cut equal sized pieces of beetroot using a cork borer.
2. Wash the pieces in running water.
3. Place the pieces in 100 cm³ of different concentrations of ethanol.
4. After 5 minutes, remove samples from each of the ethanol solutions.
5. Place each of the samples into a colorimeter to collect quantitative data.

i. Each step in the student's method relies on certain assumptions.

For each assumption listed below, select the **numbered step** from the student's method that relies upon that assumption.

Assumption A

Pigment will only leak into the solution if membranes are disrupted.

Assumption A relates to step

Assumption B

Absorbance is proportional to concentration of pigment.

Assumption B relates to step

Assumption C

Pigment will be released when the beetroot is sliced.

Assumption C relates to step

[3]

ii. The student kept the ethanol solutions at a constant temperature. State **two other** variables which need to be controlled in this investigation to ensure the data collected are valid.

1 _____

2 _____ **[2]**

(b). Fig. 20.1 shows the graph plotted by the student.

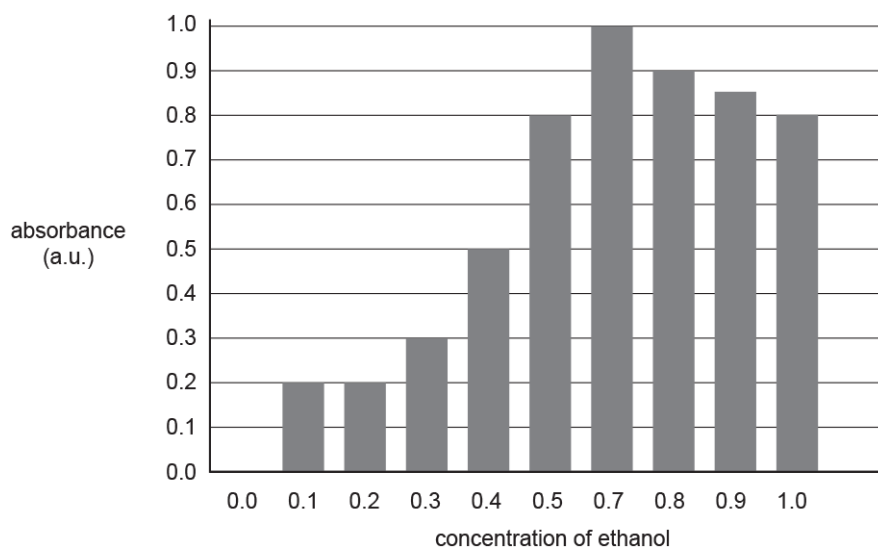

Fig. 20.1

i. Make **three** criticisms of the way the student has displayed these results.

1

2

3

- ii. Explain how carrying out replicates would improve this investigation.

[2]

28(a). A group of students investigated the effect of temperature on the membranes of beetroot cells.

A colorimeter was used to measure the concentration of purple betalain pigment that leaked out of the cells when they were exposed to different temperatures.

Table 23 shows a summary of the data collected.

Temperature (°C)	Number of readings	Mean absorbance (arbitrary units)	Standard deviation
0	10	0.04	0.01
10	10	0.04	0.02
20	10	0.04	0.02
30	10	0.06	0.02
40	10	0.09	0.03
50	10	0.21	0.06
60	10	0.44	0.18

Table 23

- i. Using the Student's *t*-test formula below, calculate the value of *t* between the data for **50 °C and 60 °C**.

$$t = \frac{|\bar{x}_A - \bar{x}_B|}{\sqrt{\frac{S_A^2}{n_A} + \frac{S_B^2}{n_B}}}$$

where:

\bar{x} is the mean
S is the standard deviation
n is the number of readings

Answer -----

[3]

- ii. The critical value for t at the significance level of 5%, with 18 degrees of freedom, is 2.10.

Use the value of t that you calculated in part (i) to explain whether the null hypothesis should be accepted or rejected.

[2]

- (b). The students plotted the data onto a graph, shown in Fig. 23.

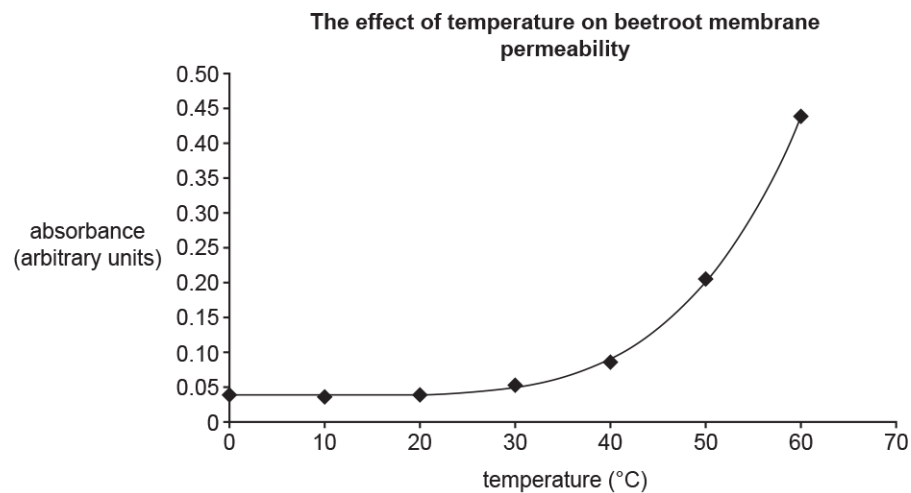

Fig. 23

Describe and explain the pattern of data shown on the graph as temperature increases.

[3]

29. A student investigated the effect of alcohol on the permeability of membranes in plant cells. The student wanted to find the minimum concentration of alcohol at which all the cells became permeable to the stain Evans Blue. Evans Blue stains the nucleus of the cell.

The student followed this method:

- The student placed samples of onion epidermis into different concentrations of ethanol.
- After five minutes a few drops of Evans Blue stain was added to each sample.
- After a further five minutes, the samples were viewed using a light microscope.
- The student observed 20 cells and recorded how many contained a blue nucleus.

Table 21.1 shows the student's results.

Concentration of ethanol (%)	Number of cells with a blue nucleus	% cells with blue nucleus
0	1	5
10	4	20
20	16	80
30	20	100
40	20	100

Table 21.1

- i. Identify **one** limitation of the method the student followed.

[1]

- ii. On evaluating the results the student decided to use a narrower range of ethanol concentrations.

Suggest what range of ethanol concentrations the student should use and give a reason for your choice.

[2]

- iii. How would using a narrower range of alcohol concentrations improve the investigation?

[1]

30. FURA-2 is a fluorescent dye that can be used to measure the concentration of Ca^{2+} ions inside cells.

The structure of FURA-2 is shown below.

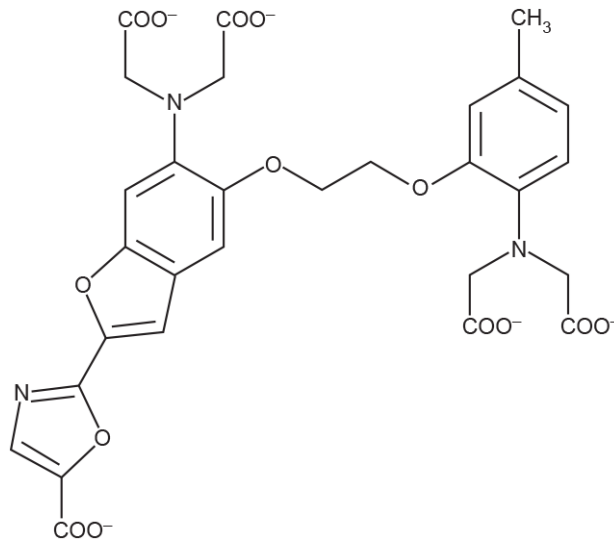

Use the information in the figure to explain why FURA-2 is unable to cross cell membranes.

[2]

31. A student investigated the uptake of two different substances in cultured cells.

The rate of uptake was measured at different concentrations of each substance in the medium surrounding the cells.

The results are shown in Fig. 16.2.

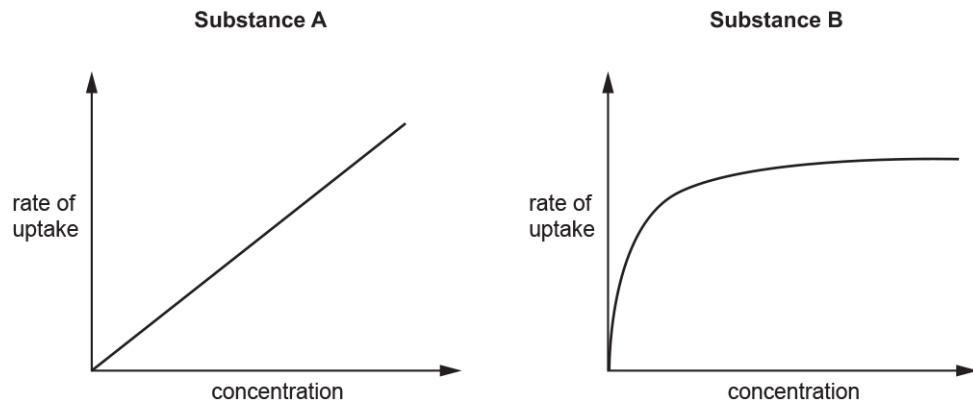

Fig. 16.2

- i. The student concluded that one substance entered the cells by simple diffusion and the other by active transport.

Evaluate the student's conclusion.

- ii. The student then added 2,4-dinitrophenol (DNP) to the cells. DNP inhibits respiration.
Predict the effect of DNP on the uptake of each substance and explain your prediction.

Substance A

effect

explanation

Substance B

effect

explanation

[4]

32(a). A group of students set up the apparatus shown below to test the effect of temperature on the rate of diffusion of glucose molecules in model cells.

They determined the concentration of glucose in the distilled water by taking samples at 30s intervals. They carried out the Benedict's test on each sample and used a calibrated colorimeter to determine the absorbance of each sample. Previously they had produced a calibration curve of colorimeter readings against glucose concentration. They used the calibration curve to determine the glucose concentrations of their samples.

They carried out the investigation at three different temperatures.

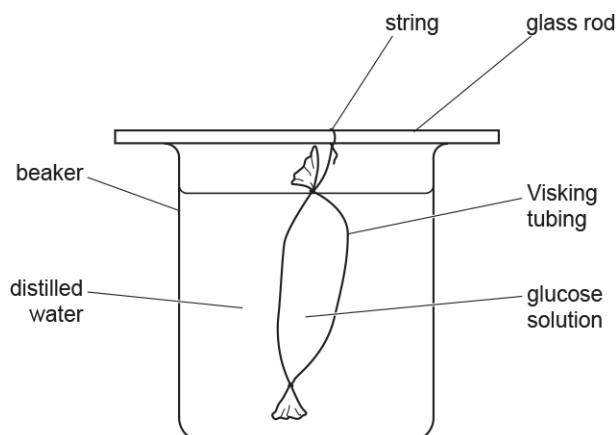

A table of the results from the students' investigation is shown below.

Temperature of water bath (°C)	Concentration of glucose found in the distilled water samples taken at 30s intervals (mmol dm ⁻³)				
	0s	30s	60s	90s	120s
10	0.00	0.33	0.65	0.98	1.30
20	0.00	0.80	3.21	2.40	3.20
30	0.00	1.23	2.45	3.68	4.90

- i. Suggest an improvement to the method that would allow the students to obtain more precise results.

[1]

- ii. State **one** variable that should have been controlled during this experiment.

[1]

(b).

- i. Before the students began their investigation they made a hypothesis.

State the hypothesis the students would have made **and** state the scientific process that supports your choice.

Hypothesis

Scientific process

[2]

- ii. Justify whether the results from the investigation support your hypothesis given in part **(b)(i)**.

[2]

(c). Describe how you would use the same equipment to test if the thickness of the exchange surface affects the diffusion rate.

[2]

33(a). Biological processes can be investigated using models.

The effect of cell size on diffusion can be investigated using cubes of agar jelly to represent cells of different sizes.

A student used cubes of agar jelly containing universal indicator, which changes colour at different pH.

- Five different sizes of cubes were cut from a larger block using a scalpel.
- Cubes were placed in a beaker containing hydrochloric acid (enough to cover the cubes) and a stopwatch was started.
- After 2 minutes the cubes were removed, rinsed with distilled water and blotted dry.
- Acid absorbed at the outside continued diffusing towards the centre of the blocks.
- The time taken for the blocks to turn entirely red was recorded.

The results are shown in **Table 22.1 on the insert.**

Cube	Length of one side of agar cube (mm)	Surface area to volume ratio	Time taken to turn red (min)			
			Test 1	Test 2	Test 3	Mean
A	5	1.20	6.4	2.9	5.4	4.9
B	10	0.60	14.8	15.5	14.6	15.0
C	20	0.30	30.6	28.3	27.4	28.8
D	30	0.20	44.1	42.2	43.0	43.1
E	40	0.15	58.7	60.1	57.4	58.7

Table 22.1

What was the role of the universal indicator in this experiment?

[1]

(b).

- i. In the space provided, plot a graph of mean time taken to turn red against surface area to volume ratio.

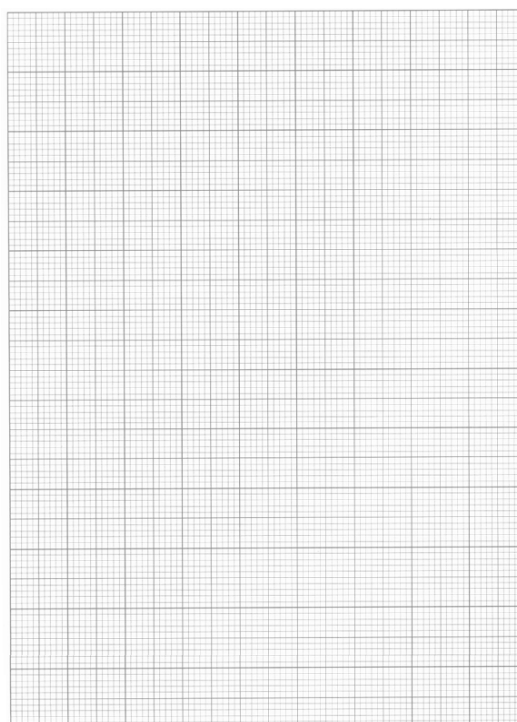

[4]

ii. Describe the pattern shown by your graph.

[1]

iii. An identical procedure was carried out on a cube of unknown size. This cube turned red after 21.5 min.

Use your graph to estimate the surface area to volume ratio of this unknown cube.

Answer..... [1]

iv. Suggest how the original procedure could be modified in order to improve the accuracy of your answer to part (iii).

[1]

(c). Use the data in **Table 22.1, on the insert**, to calculate the **rate** of diffusion of acid in **Cube C** from the outer surface to the centre of the cube.

Answer..... [3]

(d).

i. Explain which of the mean values, **A–E**, is likely to be the least accurate. You should process data from the table to support your answer.

[2]

- ii. Identify one limitation in the practical procedure that may have caused the results to be inaccurate **and** explain which cube's results are most likely to have been affected by this limitation.

Limitation

Is more likely to affect cube because

[3]

(e). The procedure described above involved the use of model cells. Hydrogen ions from the acid were able to travel freely to the centre of the agar jelly cubes.

The rate of movement of molecules from the plasma membrane towards the centre of **living** cells is often **greater** than that seen in the procedure the student carried out even if the cells are kept at the same temperature.

Suggest a reason for this observation.

[1]

34(a). A student carried out an investigation into the effect of different concentrations of sucrose on tissue from different vegetables.

Four different vegetables were cut into slices. The slices were placed into solutions containing different concentrations of sucrose. The change in mass of the slices was measured after a set period of time.

The results are shown in Table 20.

Vegetable	Concentration of sucrose (mol dm^{-3})	Mass at start (g)	Mass at end (g)	Change in mass (%)
Potato	0.0	3.56	4.38	23.03
	0.5	4.76	4.81	1.05
	1.0	2.93	2.81	-4.10
	1.5	4.56	3.99	-12.50
	2.0	3.44	2.78	-28.77
Butternut squash	0.0	6.34	6.36	0.32
	0.5	4.32	4.21	-2.55
	1.0	3.54	3.10	-12.43
	1.5	2.98	2.02	-32.21
	2.0	3.77	2.36	-37.40
Swede	0.0	4.01	5.23	30.42
	0.5	5.76	6.34	10.07
	1.0	4.33	4.56	5.31
	1.5	3.98	3.94	-1.01
	2.0	5.09	4.74	-6.88
Parsnip	0.0	6.66	6.69	0.45
	0.5	4.56	4.57	0.22
	1.0	5.67	5.66	-0.18
	1.5	3.99	3.77	-5.51
	2.0	4.81	4.00	-16.84

Table 20

- i. The student has made an error with one calculation from the potato samples. Calculate the correct value. Show your working.

Answer = [3]

- ii. Estimate the concentration of sucrose in the cytosol of swede cells.

..... [1]

- iii. What other factor will change as the concentration of the sucrose solutions changes?

..... [1]

(b). Describe how the student should represent the data from Table 20 as a graph **and** explain why this is the correct way to represent these data.

[3]

(c). Considering the data in Table 20, suggest **three** improvements to the design of this experiment. For each improvement explain how it will increase the validity of the data collected.

improvement 1:

explanation:

improvement 2:

explanation:

improvement 3:

explanation:

[6]

35(a). A student investigated the effects of different solutions on pieces of potato tissue. Six potato rods were prepared with a cork borer. The student trimmed them to a length of exactly 5 cm.

After treatment, the six rods were placed in test tubes and submerged in either sucrose solution or distilled water.

The treatment and liquid added to each potato rod is shown in Table 21 below.

Potato rod	Treatment	Liquid added
A	boiled in water for 5 minutes	1 mol dm ⁻³ sucrose solution
B	boiled in water for 5 minutes	distilled water
C	soaked in ethanol for 5 minutes	1 mol dm ⁻³ sucrose solution
D	soaked in ethanol for 5 minutes	distilled water
E	untreated	1 mol dm ⁻³ sucrose solution
F	untreated	distilled water

Table 21

After 30 minutes, the rods were removed from the tubes and their lengths measured.

The student recorded the results on a piece of scrap paper, shown below.

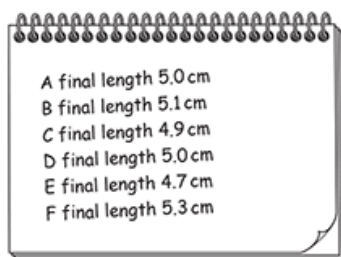

In the space below, present the student's results in an appropriate format.

(b).

- i. Explain how the treatment results in the difference in the final lengths of rod **A** and rod **E**.

[2]

- ii. Explain how the treatment results in the difference in the final lengths of rod **D** and rod **F**.

[2]

- (c).** State how the student could reduce the uncertainty of their data.

[1]

36(a). Water moves by osmosis in living organisms.

- i. Define osmosis.

[2]

- ii. Plants rely on osmosis for support.
 Explain the importance of osmosis in plant support.

[3]

(b). The apparatus shown in Fig. 16 can be used to demonstrate osmosis.

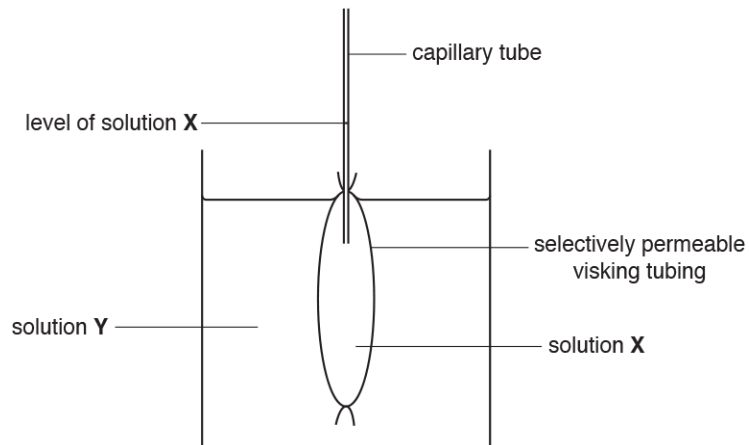

Fig. 16

When the capillary tube with visking tubing bag was placed in solution Y, the level of solution X inside the capillary tube rose from 10.5 mm to 26.5 mm.

- i. The ruler used to measure the distance along the capillary tube was accurate to the nearest 0.5 mm.
Calculate the percentage uncertainty of the measurement.

uncertainty = % **[2]**

- ii. What conclusions can be drawn about the composition of solutions **X** and **Y**?

[2]

- (c). A group of students used the following method to investigate osmosis in plant cells.

- Cut pieces of plant material of equal surface area ensuring no skin is present.
- Rinse to remove cell debris.
- Gently pat the plant pieces dry with a paper towel.
- Weigh each piece and record mass.
- Put the plant piece in a 200 cm³ beaker.
- Cover plant piece with 50 cm³ of sucrose solution.
- Use sucrose solutions of 0, 0.1, 0.3, 0.5, 0.7 mol dm⁻³.
- Leave for 24 h.
- Remove the piece of plant material.
- Dry carefully using a paper towel.
- Weigh the plant piece and record the mass.
- Calculate the percentage change in mass for each piece.
- Repeat twice for each sucrose concentration.

The students investigated material from three different plants: carrot, courgette and potato.
Their results are shown in Table 16.

- i. Explain why it was necessary to calculate **percentage** change in mass.

[2]

Plant	Sucrose concentration /mol dm ⁻³	Percentage change in mass			
		Replicate 1	Replicate 2	Replicate 3	Mean
Carrot	0	+ 6.0	+ 5.8	+ 5.8	+ 5.87
	0.1	+ 4.2	+ 4.1	+ 4.3	+ 4.20
	0.3	+1.5	+1.5	+1.3	+ 1.43
	0.5	- 2.4	- 2.3	- 2.1	- 2.27
	0.7	- 6.3	- 6.1	- 6.3	- 6.23
Courgette	0	+ 7.9	+ 7.8	+ 7.6	+ 7.77
	0.1	+ 5.5	+ 5.5	+ 5.5	+ 5.50
	0.3	+ 1.9	+ 1.8	+ 2.0	+ 1.90
	0.5	- 1.2	- 1.4	- 1.1	- 1.23
	0.7	- 4.3	- 4.4	- 4.1	- 4.27
Potato	0	+ 5.7	+ 5.8	+ 5.7	+ 5.77
	0.1	+ 3.1	+ 2.9	+ 3.0	+ 3.00
	0.3	- 0.3	- 0.4	- 0.6	- 0.43
	0.5	- 2.4	- 2.2	- 2.5	- 2.37
	0.7	- 6.1	- 5.9	- 5.1	- 5.70

- ii. The students identified replicate 3 of the potato in 0.7 mol dm⁻³ sucrose as anomalous.

Suggest a practical error by the students that might have caused this result to be anomalous and explain the likely effect of this error.

[2]

iii. Use Table 16 to identify which plant cells contained the highest concentration of sucrose.

Justify your conclusion.

[3]

37. The figure shows some of the apparatus used in an experiment investigating water potential in potato tuber tissue.

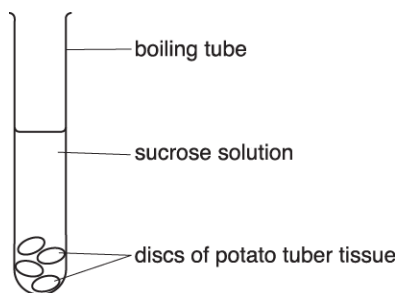

The discs were placed in boiling tubes containing sucrose solutions of different concentrations for four hours. The percentage change of mass was then calculated.

The results are shown in the table.

Concentration of sucrose solution (mol dm^{-3})	Change in mass of potato discs (%)
0.00	+18.00
0.10	+12.50
0.20	+2.50
0.30	- 3.00
0.40	- 8.00
0.45	-11.50

i. State **two** details of the procedure that must be followed to obtain valid results.

1: -----

2: -----

ii. Explain how a student could use the data in the table to determine the water potential of the potato tuber tissue.

